

RoHS

本产品符合我司QA-3-04-005
环境管理物质标准规范

包装图

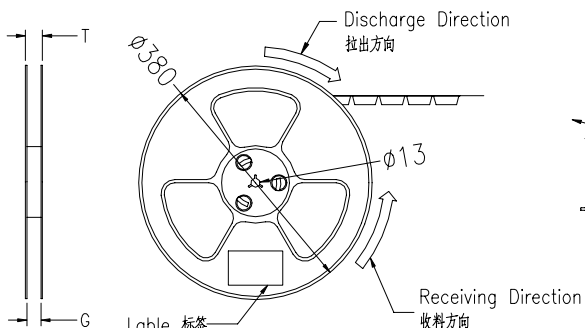
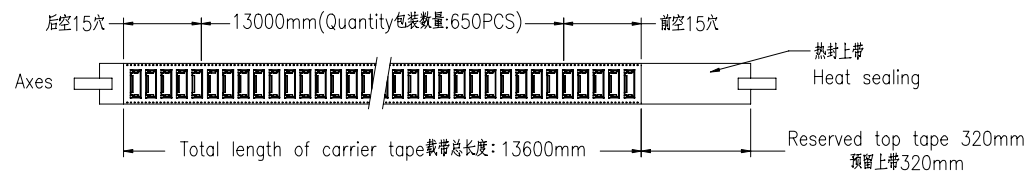

COVER TAPE PEEL STRENGTH: 20~120g
剥离力量 20~120g
速度 PEEL SPEED: 300mm/minute

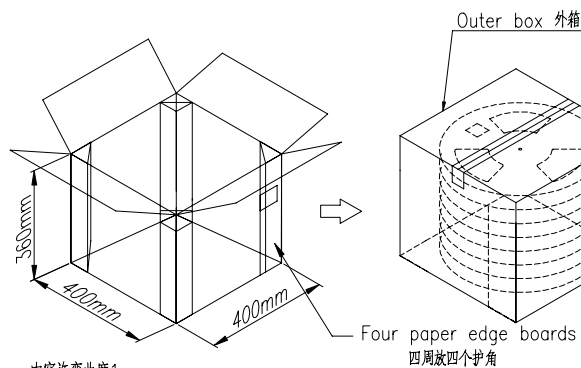
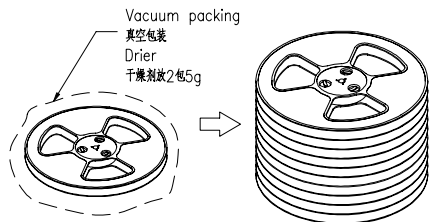
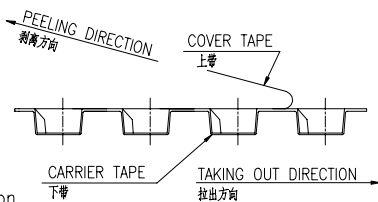

Pull out direction 拉出方向

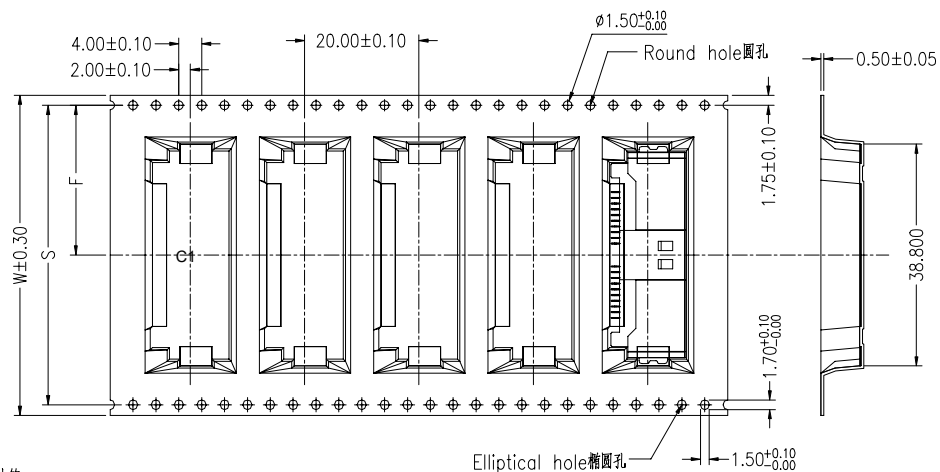

Width 载带宽度 W=56mm

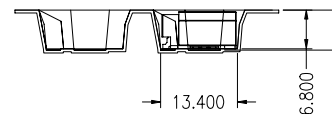

Note:

- Carrier Camber Is Within 1mm In 100mm ; 带长100mm内容许弯曲度1mm
- 10 Sprocket Hole Pitch Cumulative Tolerance ±0.2MM ; 圆孔十个孔距累积允许公差为±0.2mm
- Carrier tape material: PS, thinkess=0.50±0.05mm, color: lucency.
载带材质: PS, 厚度=0.50±0.05mm, 颜色: 透明色.
- Bracer material: PS, thinkess=0.40±0.05mm, color: lucency.
保护带材质: PS, 厚度=0.40±0.05mm, 颜色: 透明色.
- Cover tape material: PET, Heat sealing.
上带材质: PET, 热封.
- Reel material: PS, color: blue. 卷盘材质: PS, 颜色: 蓝色.
- Carton material 纸箱材质: K=K; Carton Thickness 纸箱厚度: 6~7mm

Applicable Product No. 适用产品料号	1044WRS-20A/B/C-LPXXXXR
----------------------------------	-------------------------

Carrier Tape No. 载带料号	W	S	F	T	G	REEL PCS/卷	CARTON 卷/箱	CARTON PCS/箱
ZD1044WRS-20HF	56	52.40	26.20	60.5	56.5	650	5	3250

SMS 东莞市思索技术股份有限公司
Dongguan SESO Technology Co., Ltd.

料号: CTN: ZD1044WRS-20HF
PPN: 1044WRS-20X-LPXXXXR

名称: 1.00mm Crimp Style Connectors Packing

核准	审查	制作	日期
杨蒙	莫光培	滕敏	2023/10/14

单位	比例	页次	版本	编号
mm	1:1	1/1	A0	A-000

20231014	A0	/	首次发行	/	杨蒙
日期	版次	变更编号	变更内容说明	变更人	核准

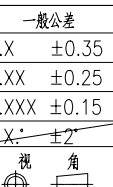

RoHS

本产品符合我司QA-3-04-005
环境管理物质标准规范

包装图

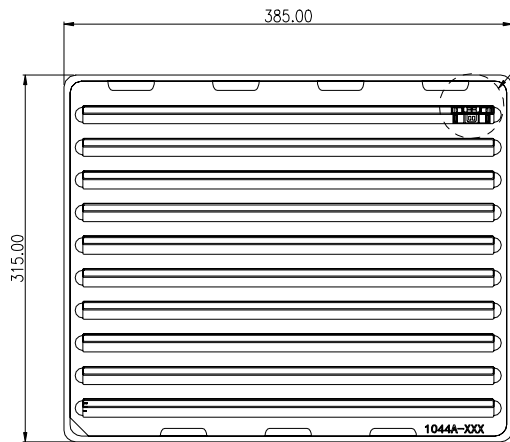

DETAIL A

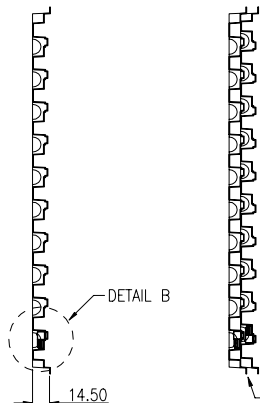

DETAIL B

Overlap the uptake plastic tray
上下盘需错盘堆叠

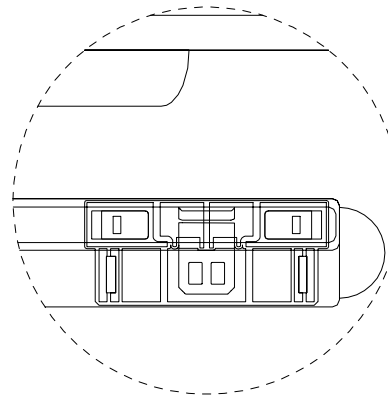

DETAIL: A
6:1

Product Matching Diagram
产品摆放示意图

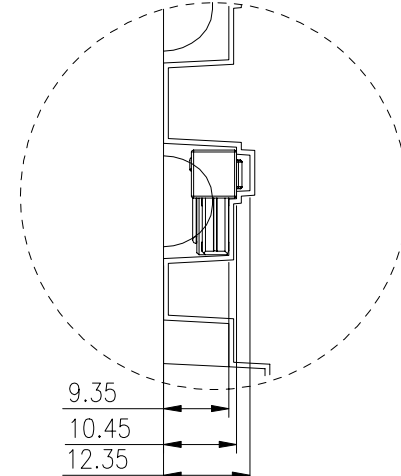

DETAIL: B
6:1

Step步骤:1

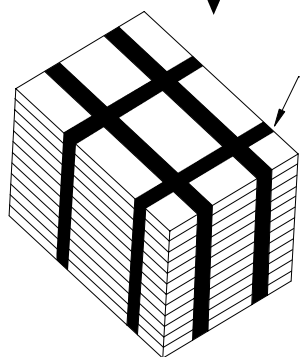

PE film shaft winding
PE膜井字型缠绕

Step步骤:2

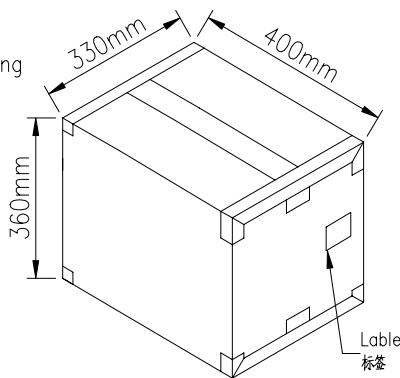

Step步骤:3

Packing step包装步骤:

Step 1: Place the inspected product arrange neatly and in the same direction into the uptake plastic tray, the quantity cannot be reduced.

步骤1: 将检验好的良品整齐并方向一致地摆放入吸塑盘,不可少数。

Specification of the uptake plastic tray: 385*315*14.5mm

吸塑盘规格: 385*315*14.5mm

the Part Number of uptake plastic tray: 1044ASP-3850*3150*145

吸塑盘料号: 1044ASP-3850*3150*145

Step 2: Overlap the uptake plastic tray, When it overlaps, adjacent upper and lower tray need to be rotated 180 degrees for stacking, one empty uptake plastic tray is stacked together in every 32 products, and put one on the top layer as well, fold them up into a bundle, then cross and parallel wrap with PE film.

步骤2: 将吸塑盘错盘重叠, 注意在重叠吸塑盘时, 相邻上下两盘需要旋转180度堆叠, 每32盘产品加最顶层放1PCS空吸塑盘叠起来为1扎, 然后用PE膜井字型缠绕。

Step 3: Put 1 bundle of PE film in a carton, seal the carton with transparent tape, attach outer carton label.

步骤3: 一箱里放入PE膜捆好的1扎产品, 然后用透明胶带封箱, 贴上外箱标签。

Note: when the carton is not full, filling material is required, cannot shake too much.

注: 不满箱时, 需使用填充物, 不可晃动太大。

Carton size: CB-400*330*360KK-01

纸箱规格: CB-400*330*360KK-01

Carton material: K=K

纸箱材质: K=K; 纸箱厚度: 6~7mm

Applicable Product No. 适用产品料号	Poles Pin位	Pcs/Tray Pcs/盒	Tray/Carton 盒/箱	Pcs/Carton Pcs/箱
1044A-20A-PTXXT	20Pin	100	32	3200

日期	版次	变更编号	变更内容说明	变更人	核准
20231128	A0	/	首次发行	/	杨蒙

一般公差	
.X	±0.35
.XX	±0.25
.XXX	±0.15
X:	±2°

SMS 东莞市思索技术股份有限公司
Dongguan SESO Technology Co., Ltd.

核准	审查	制作	日期
杨蒙	杨梅 莫光培	何琴	20231128

料号: PK-1044A-XXX-PTXXT				
名称: 1.00mm Pitch Housing Packing				
单位	比例	页次	版本	编号
mm	1:1	1/1	A0	A-398