

RoHS

本产品符合我司QA-3-04-005
环境管理物质标准规范

包装图

F
E
D
C
B
A

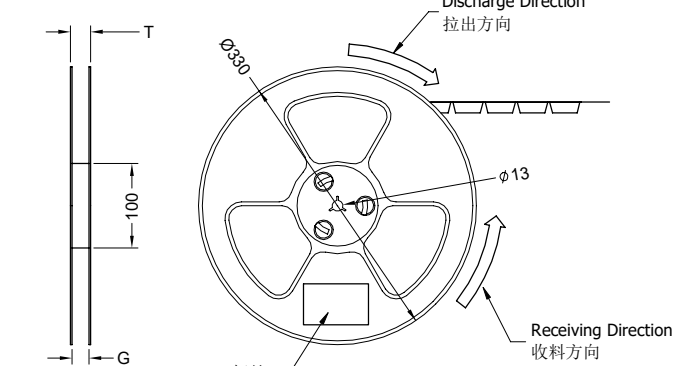
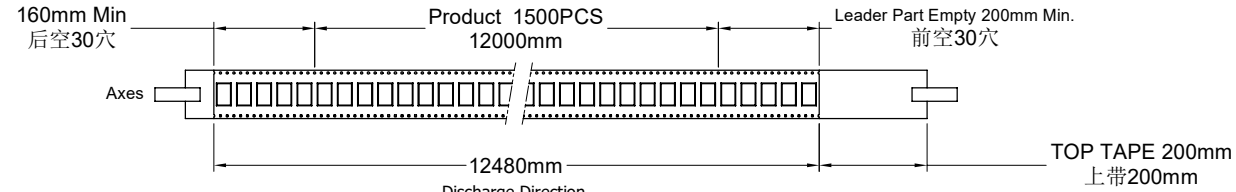

Single hole: None Hole Side
单孔: 贴无链孔侧
Double hole: Elliptical Hole Side
双孔: 贴椭圆孔侧

COVER TAPE PEEL STRENGTH:20~120g
上带剥离力量:20~120g
速度 PEEL SPEED:300mm/minute

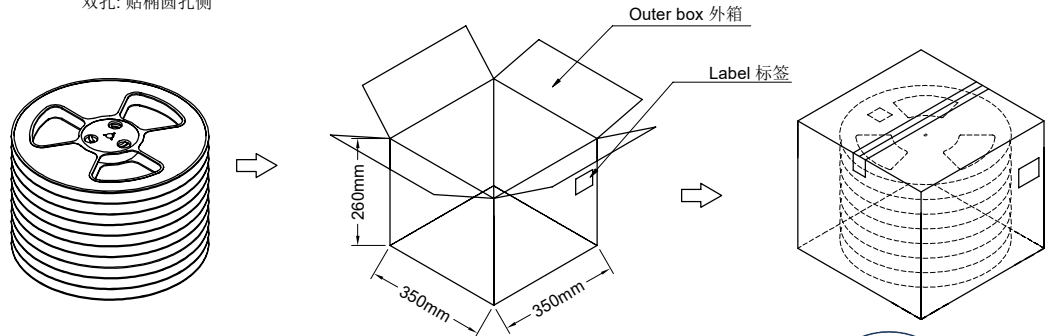
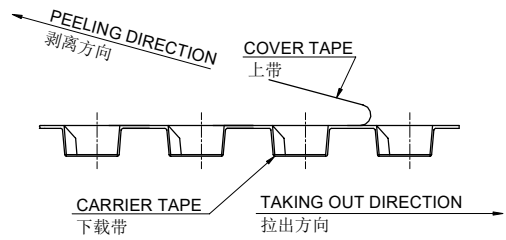

- Note:
- Carrier Camber Is Within 1mm In 100mm ; 带长100mm内容许弯曲度1mm
 - 10 Sprocket Hole Pitch Cumulative Tolerance±0.2MM ; 圆孔十个孔距离累计允许公差为±0.2mm
 - Carrier tape material for PS ; 下带材质为PS材质; Color颜色:Natural透明色
 - bracer保护带: Color颜色:Natural透明色,厚度0.40mm最小
 - Thinkess=0.40±0.05 ; 材料厚度为0.40±0.05mm
 - Carton material纸箱材质:K=K; Carton Thickness纸箱厚度: 6~7mm

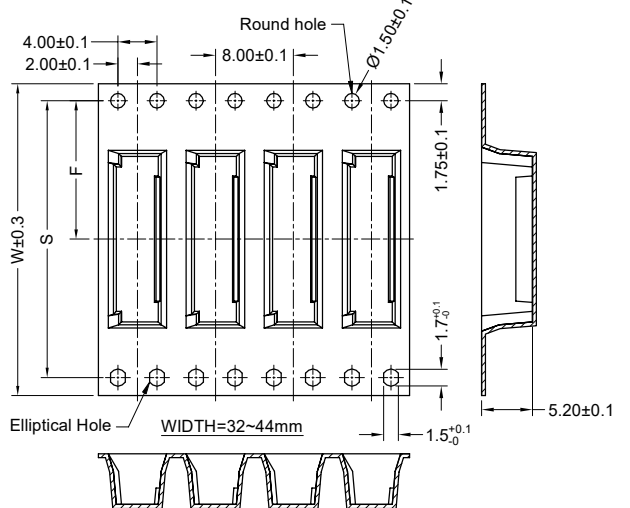
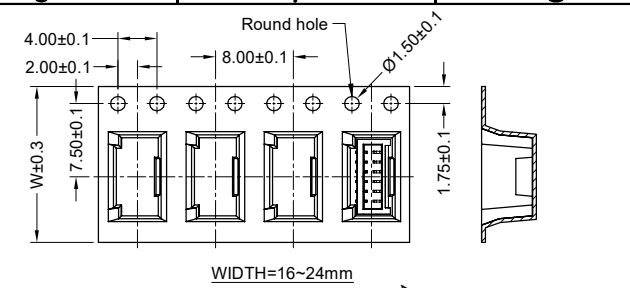

Part No.	W	S	F	T (MAX)	G (MAX)	REEL /PCS	CARTON /R	CARTON /PCS
ZD1002WVS-02BHF	16	/	7.50	20.50	16.40	1500	11R	16.5K
ZD1002WVS-03BHF								
ZD1002WVS-04BHF								
ZD1002WVS-05BHF								
ZD1002WVS-06BHF								
ZD1002WVS-07BHF	24	/	11.50	28.50	24.40	1500	8R	12K
ZD1002WVS-08BHF								
ZD1002WVS-09BHF								
ZD1002WVS-10BHF								
ZD1002WVS-11BHF								
ZD1002WVS-12BHF	32	28.40	14.20	36.50	32.40	1500	6R	9K
ZD1002WVS-13BHF								
ZD1002WVS-14BHF								
ZD1002WVS-15BHF								
ZD1002WVS-16BHF								
ZD1002WVS-17BHF	44	40.40	20.20	48.50	44.40	1500	5R	7.5K
ZD1002WVS-18BHF								
ZD1002WVS-19BHF								
ZD1002WVS-20BHF								

日期	版次	变更编号	变更内容说明	变更人	核准
2020/03/14	C	EN20200314001	Update Drawing Frame	Wzbin	Robing
2019/03/19	B	ER20190319001	依实物修改载带型腔形状	Joshua	Smarm

一般公差	
.X	±0.30
.XX	±0.20
.XXX	±0.10
X	±0.2

东莞市思索连接器有限公司
SWB CONNECTORS CO.,LTD

核 准: Kim Huang
审 查: Jova Lau
制 作: Allen
日 期: 2013/12/09

料 号: PPN: 1002WVS-XXBX-XXXX
CTN: ZD1002WVS-XXBHF

名 称: 1.00mm Connectors SMT 180° Package

单位	比例	页次	版本	供应商编号
mm	1:1	1/1	C	A-106

F
E
D
C
B
A

1 2 3 4 5 6 7 8

RoHS

本产品符合我司QA-3-04-005
环境管理物质标准规范

包装图

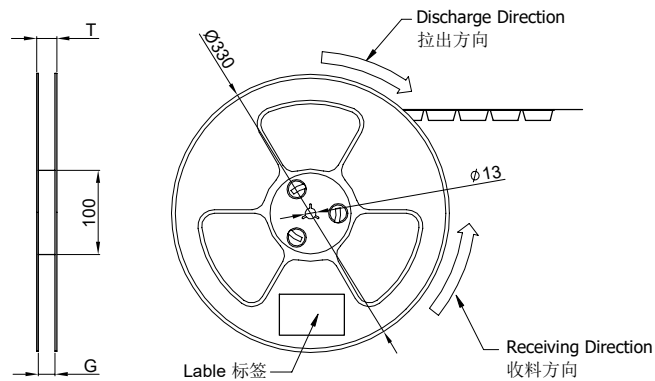
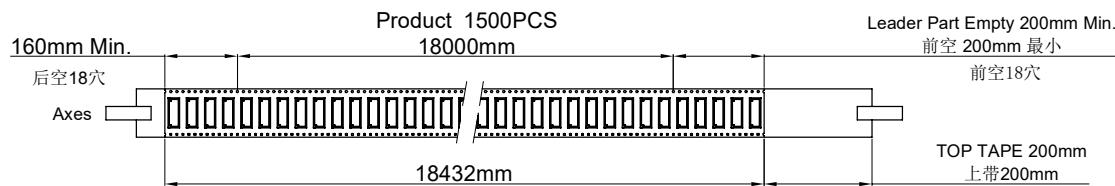

COVER TAPE PEEL STRENGTH:20~120g
上带剥离力量:20~120g
速度 PEEL SPEED:300mm/minute

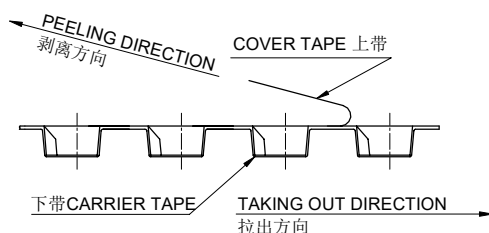

Single hole: None Hole Side
单孔: 贴无链孔侧
Double hole: Elliptical Hole Side
双孔: 贴椭圆孔侧

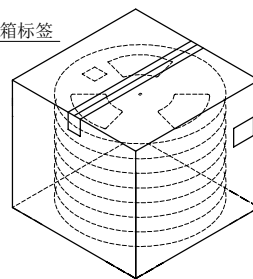
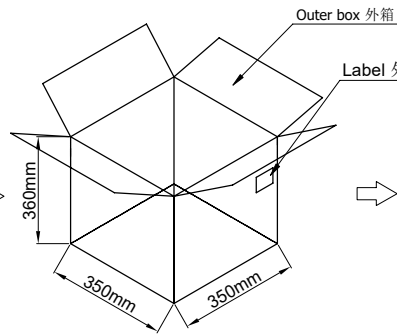
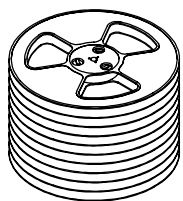
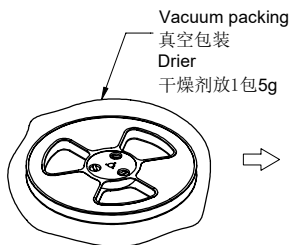

- Note:
- Carrier Camber Is Within 1mm In 100mm ; 带长100mm内容许弯曲度1mm
 - 10 Sprocket Hole Pitch Cumulative Tolerance±0.2MM ; 圆孔十个孔距离累计允许公差为±0.2mm
 - Materiaal for PS ; 材质为PS材质 ; Color颜色: Natural透明色
 - bracer保护带: Color颜色:Natural透明色
 - Thinness=0.30±0.05 ; 材料厚度为0.30±0.05mm
 - Carton material纸箱材质:K=K; Carton Thickness纸箱厚度: 6~7mm

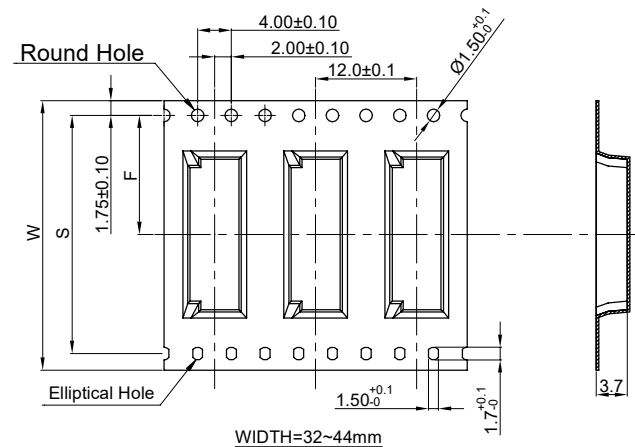
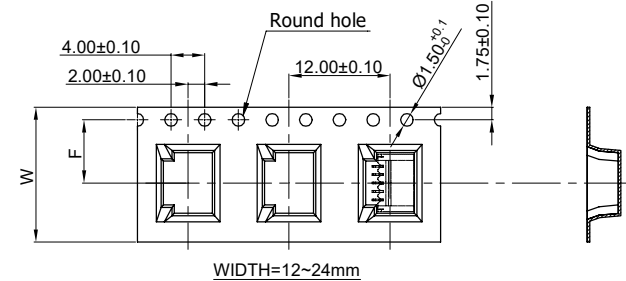

Part No.	W	S	F	T (MAX)	G(MAX)	Cover Tape(宽度) 上带(W)	Carrier Tape(Color) 下带(颜色)	REEL /PCS	CARTON /R	CARTON /PCS
ZD1002WRS-02BHF	12	/	4.50	16.50	12.40	9.3		1500	21R	31.5K
ZD1002WRS-03BHF										
ZD1002WRS-04BHF										
ZD1002WRS-05BHF	16	/	7.50	20.50	16.40	13.3		1500	17R	25.5K
ZD1002WRS-06BHF										
ZD1002WRS-07BHF										
ZD1002WRS-08BHF										
ZD1002WRS-09BHF										
ZD1002WRS-10BHF										
ZD1002WRS-11BHF	24	/	11.50	28.50	24.40	21.3	透明色	1500	12R	18K
ZD1002WRS-12BHF										
ZD1002WRS-13BHF										
ZD1002WRS-14BHF										
ZD1002WRS-15BHF										
ZD1002WRS-16BHF										
ZD1002WRS-17BHF	32	28.40	14.20	36.50	32.40	25.5		1500	9R	13.5K
ZD1002WRS-18BHF										
ZD1002WRS-19BHF										
ZD1002WRS-20BHF	44	40.40	20.20	48.50	44.40	37.5		1500	7R	10.5K

2020/03/14	B	EN20200314001	Update Drawing Frame	Wzbin	Robing
日期	版次	变更编号	变更内容说明	变更人	核准

一般公差
X ±0.30
.XX ±0.20
.XXX ±0.10
X ±0.2

视角

东莞市思索连接器有限公司
SWB CONNECTORS CO.,LTD

核准 审查 制作 日期
Smak Joshua Alan qin 2018/05/22

料号: PPN: 1002WRS-XXBX-XXXX
CTN: ZD1002WRS-XXBXHF

名称: 1.00mm Connectors SMT 90° Packing

单位	比例	页次	版本	供应商编号
mm	1:1	1/1	B	A-000